

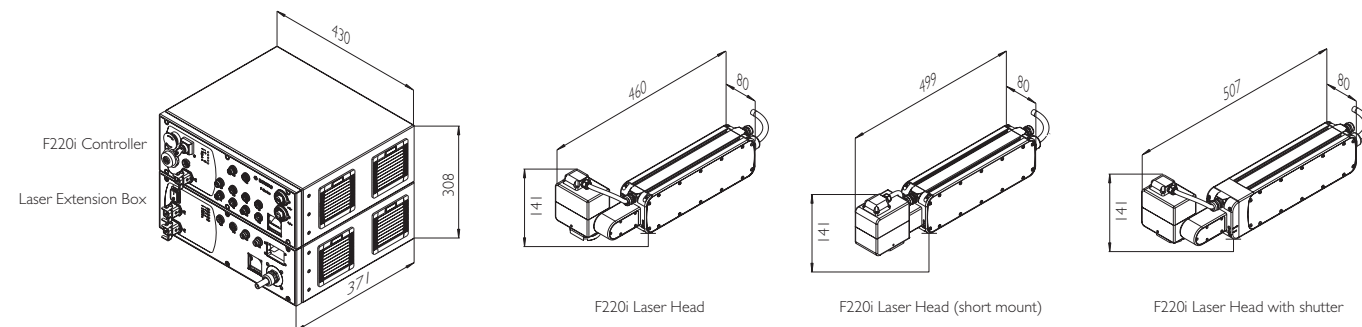

Technical Specification:

| F220i | |
|---|---|
| Laser Type | Pulsed Fibre Laser with adjustable waveform (expected laser source life of over 100,000 hours) |
| Laser Wavelength | 1059 - 1065nm |
| Laser Power | 20W (Maximum Average Output Power) |
| Pulse Peak Power | More than 12 kW |
| Marking Features | |
| Characters per Second | 2000* |
| Product Line speed | 600m/min* (1970ft/min*) |
| Number of Lines of Text | As many as desired |
| Character Height | 0.3mm (0.01in) to size of marking field |
| Fonts & code types | 24 fonts, multi-language including Unicode, logos, bar codes, 2D codes, graphics |
| Marking Field | 118 x 118mm, 229 x 229mm (4.6 x 4.6in, 9.0 x 9.0in) |
| Focal Length / spot size | 160mm (6.3in) / ~70µm, 300mm (11.8in) / ~130µm |
| User Interface | |
| Web Browser-based Graphical User Interface (GUI) (optional TouchPanel available) WYSIWYG entry, control language in English, German, French, Czech, Danish, Spanish, Finnish, Greek, Hungarian, Italian, Japanese, Dutch, Portuguese, Polish, Chinese, Korean, Romanian, Russian, Swedish, Slovak, Turkish, Arabic | |
| Operating System | |
| Windows CE | |
| Marking Software | |
| Dynamark III Laser Marking Software | |
| Scan Head | |
| i-Tech Scan Head, mountable in various orientations including axial and radial | |
| Laser Head | |
| Stainless steel and anodised aluminium construction | |
| Weight & Dimensions (approx.) | |
| Laser Head | 6.7kg, 460 x 80 x 141mm (14.8lbs 18.1 x 3.1 x 5.6in) |
| Laser Head with shutter (WxDxH) | 6.9kg, 507 x 80 x 141mm (15.2lbs 20.0 x 3.1 x 5.6in) |
| Laser Extension Box | 21.0kg, 430 x 371 x 154mm (46.3lbs 16.9 x 14.6 x 6.1in) |
| Controller | 14.5kg, 430 x 371 x 154mm (32.0lbs 16.9 x 14.6 x 6.1in) |
| Fibre and conduit | 2.7m (8.9ft) between laser extension box and laser head |
| Inputs & Outputs | |
| Product Detect Inputs | NPN / PNP / 24V – Sensor |
| Product Speed Detect | Shaft Encoder (differential) or Steady Signal |
| Signal Inputs / Outputs | Laser Ready, Busy Signal, fume extractor control, compressed air control |
| Interfaces | |
| RS232, Ethernet (10/100 MBit), USB Port | |
| Electrical Requirements | |
| 90-264V, 47-63Hz, 1120VA | |
| Environment | |
| Controller | Standard Version (air cooled, fan) |
| Laser extension Box | Standard Version (air cooled, fan) |
| Laser head | IP65 protected version (no cooling required) |
| Environmental Standard Operating | Operating Temperature 5° to 40° C (41° to 104° F) / higher temperatures on request. Operating Humidity Max. 90% RH, non-condensing |
| Options | |
| Aiming Beam, User Port Kit I/O, Fume Extraction Shroud, Shutter, Connecting Cable Kit 0.5m (1.6ft) optional: 4.5m (14.8ft), 9m (29.5ft), USB Image Backup/Restore Kit, Rack Mounting Kit, Daisy-Chaining, i-Tech RapidScan technology | |

All data regarding wave form 0 *Substrate, pitch and code dependent **Dimensions measured overall for shortest version



The F220i fibre laser

Maximising performance, extending possibilities

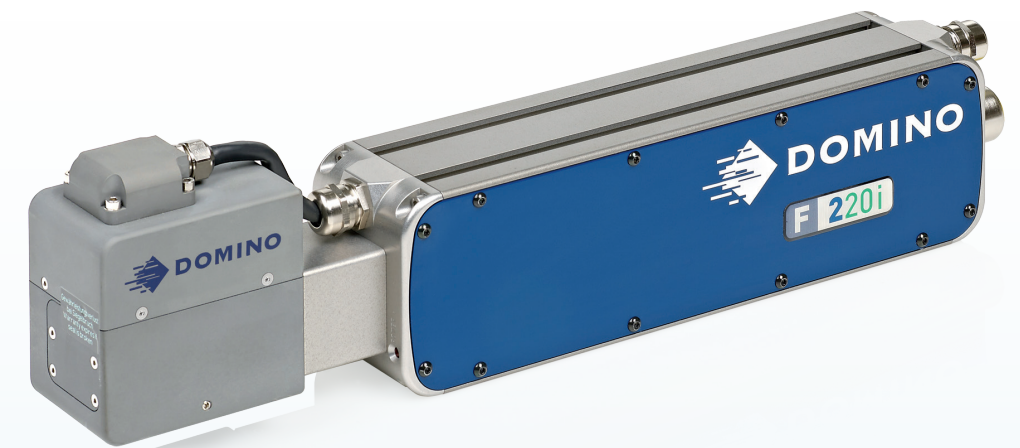

The compact fibre version of our **i-Tech** range of lasers gives you utmost performance when it comes to high precision marking of your products.

www.dominosystems.dk

F220i/1119 All performance-related figures and claims quoted in this document were obtained under specific conditions and may only be replicated under similar conditions. For specific product details, you should contact your Domino Sales Advisor. This document does not form part of any terms and conditions between you and Domino.

Domino Systems A/S
Marielundvej 46A
2730 Herlev
Tlf.: (+45) 70 20 64 16
kontakt@dominosystems.dk



Domino. Do more.

Performance and value

Domino's advanced **F220i** fibre laser system incorporates many of our proven **i-Tech** laser components and the latest fibre technology, ensuring great performance. Its compact footprint makes it easy to install.

With the **F220i** you can permanently mark a wide range of materials, such as metal, plastics and flexible packaging with the utmost precision and quality.

Compared to traditional solid state lasers the **F220i** laser does not require planned maintenance giving a lasting performance. The fibre laser has an expected life of approximately 100,000 hrs, ensuring the highest uptime.

A diverse range of applications

The **F220i** laser system produces unlimited lines of text in any orientation, and in many fonts and sizes. It is equally suitable for both graphics and 2D datamatrix codes. All are permanently applied on e.g. metal and plastic materials with high precision. The **F220i** is equally suited for static / intermittent coding and "marking on the fly" applications from low to high production line speeds.



High contrast marking on various plastics – colour change, engraving



Flexible packaging – colour change, top layer removal



Ideal for metal marking – colour change, engraving, annealing

Greener credentials

Domino's commitment and investment in sound environmental practices means we frequently exceed the demanding governmental, industry and company standards and regulations. We are committed to minimising the consumption of natural resources and energy and the creation of waste. Additionally, our products are RoHS and WEEE compliant so that they are recyclable.

F220i

The **F220i** offers contactless coding with no need for consumables – this minimises waste and helps you to reduce your carbon footprint. Long life ensures less waste on electronic parts.

High precision & power – for maximum quality

For crisp, sharp codes and high coding accuracy, Domino's fibre laser is second to none. The spot of the fibre laser beam is approximately 10 times finer and sharper than with other laser coding products so you can mark your products with utmost precision and quality. The **F220i** has high pulse power peaks of more than 12kW which makes it an easy job to engrave metals or to cut and micro process harder materials.

If your substrate requires a more delicate touch, the **F220i** can tailor the waveform of the laser pulse specifically to your application requirements unlike common fibre laser systems. This special property of the **F220i** makes it possible for you to achieve better contrast on plastic materials. Additionally it ensures a much softer coding process for material susceptible to fractures.

Thanks to optimised mirror and software control of the **i-Tech** scan head it is possible to combine precision and high production line speeds, making the **F220i** ideal also for mark-on-the-fly applications.



Adjustable waveform for higher contrast on plastics



High uptime – peace of mind

The **F220i** laser coding system has been built to last. It combines robustness with very long life so productivity is high. As there aren't any planned replacement routines, you don't have to worry about interrupting your production process.

The fibre laser head does not produce any heat and additional cooling is not necessary, allowing limitless performance at high production rates.

Economic, efficient and resource-saving - this versatile laser system uses less energy than other laser coding systems.

For pharmaceutical customers we offer unique user passwords and change reporting to be 21-CFR part 11 and GAMP compliant; these can be supplied and installed with validation packages.

High flexibility – for quick and smart installations

As with all proven Domino laser products, we've given careful consideration to compact sizing – so you can benefit from optimum footprint when it comes to installation. The fibre medium can be efficiently incorporated into tight housing ensuring overall smaller

dimensions. The **F220i** incorporates the flexible **i-Tech** scan head that can be rotated in multiple directions. It also offers full length integrated mounting rails on both sides of the laser - making it easy to install this compact laser even into areas where space is at a premium.

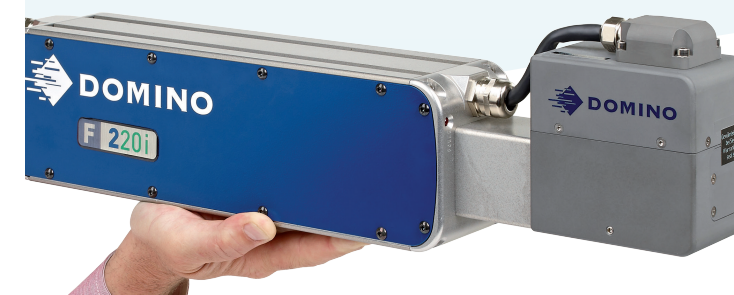

Domino. Do more.