

TRAVERSER 2S

Traverser for Continuous and Thermal Inkjet



A Traverser provides a means by which a print head can traverse a production line instead of operating statically.

MAIN FEATURES

- Programmable to allow multiple prints to be made on each cycle and modify dynamic properties to match line requirements.
- IP65 as standard, all controls are built into the axis eliminating the need for a separate control box and cabling.
- Encoder for position feedback, which will detect and correct stalls or crashes.
- Reliability - All electrical components are PCB mounted, so fewer components and fewer wires means higher reliability and easier fault finding.
- Program storage for up to 16 programs, selectable by host machine, selector switch or PC.
- Programs can be backed up to MicroSD card
- Compatible with all Domino i-tech, Ax and Gx models (Additional dovetail mount plate required for Gx)
- 5 Different Stroke lengths as standard
- High Performance model for very demanding cycle requirements and multi-head applications
- Custom units available with multiple printheads



Available Models:

Part No	Description	Domino Part No
T10780	Traverser 2S 280mm Stroke	EPT071895
T10781	Traverser 2S 440mm Stroke	
T10782	Traverser 2S 600mm Stroke	EPT071896
T10783	Traverser 2S 800mm Stroke	
T10784	Traverser 2S 1000mm Stroke	
T10785	Traverser 2S HP 600mm Stroke	
T10786	Traverser 2S HP 800mm Stroke	
T10787	Traverser 2S HP 1000mm stroke	

SETUP SOFTWARE

PC based set-up software is supplied to allow dynamic and printing parameters to be configured to suit the requirements of each installation.

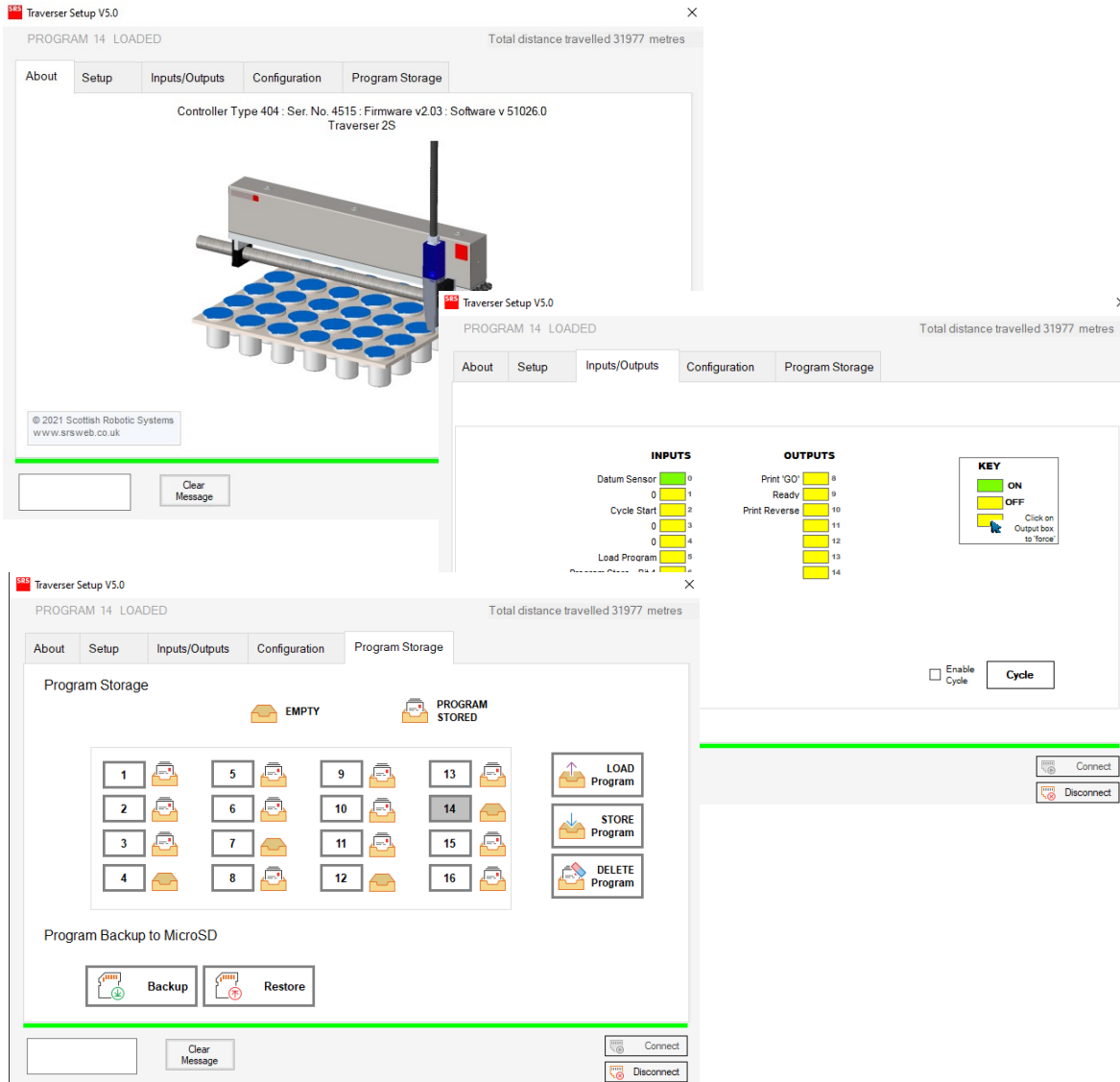

MODES OF OPERATION

The Traverser can be supplied for either Standard operation or lane-changer operation:

Standard mode Moves print head at 90° degrees to motion of product. Prints while product is momentarily stopped

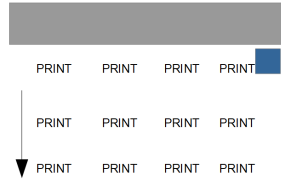

Lane Changer Mode Printing is in the same direction of movement as the product. Uses an encoder to synchronise with product movement. Prints while product is moving. Typically used on extrusion lines

NB: Lane Changer software is not provided as standard and must be requested at time of order

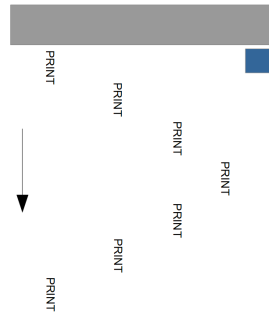

Print Mode

- Print BOTH Ways'- Prints in both directions of travel. Requires print reverse cable
- Print FROM Home'- Sets the Traverser to print away from Home,prints in one direction only
- Print To Home'- Print towards the Home position, prints in 1 direction only

For more information on print modes, see Traverser Operation and Maintenance Manual

Print Pitch

- The number of prints and the pitch between the prints can be set using Traverser Setup software.
- up to 20 prints with a fixed pitch (ie 5 prints each 50mm apart)
 - up to 10 prints with variable pitch (ie 2nd print at 30mm, 3rd at 55mm, 4th at 75mm)

Program Select

Up to sixteen programs can be stored in the Traverser. These can be selected by:

- Setup software
- Program Select Switch
- Using external IO from host machine

Programs can be saved to MicroSD card, useful for duplicating settings to another Traverser or for controller replacement

PERFORMANCE

Stroke:	Programmable up to 280/440/600/800/1000 mm
Speed:	Programmable from 10 mm/s up to 1000 mm/s
Acceleration:	Programmable from 500 mm/s/s up to 10000 mm/s/s
Duty Cycle:	100%

ENVIRONMENT

Temperature Range:	5-40°C
Humidity:	10 – 90% RH (non condensing)
Electrical Requirements:	Single Phase, 120-230 VAC, 50/60 Hz, 40VA
Protection:	All units are IP65 rated
Operating Noise:	<70 dB(A)

CONSTRUCTION

Traversers are constructed using stainless steel and anodised aluminium.

INPUTS

- Cycle Start
- 4 binary program select inputs allow 1 of 16 stored programs to be selected
- Program select input to initiate program change following change of binary inputs
- Encoder input available for lane changer operation (Not supplied as standard)

OUTPUTS

- Print Go
- Ready (Contact closure rated 2A 30vdc)
- Virtual Encoder (maintains print width during acceleration/deceleration)
- Print Reverse

STANDARD COMPONENTS

The following parts are supplied as standard

- Software USB drive and MicroSD card
- Operation and maintenance manual
- Ethernet cable
- Print Go/Encoder cable

MOUNTING DIMENSIONS

Dimensions for 32mm Diameter Round Mountings:

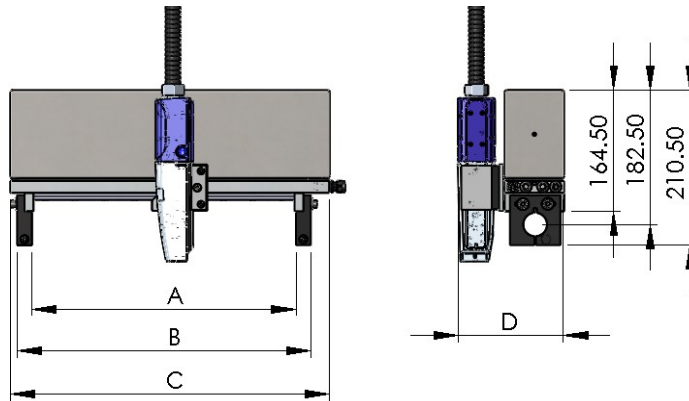

Part Number	Dimensions (mm)				
	Stroke	A	B	C	D
T10780	280	355.5	395.5	430	143
T10781	440	516	556	590	143
T10782	600	676	716	750	143
T10783	800	876	916	950	143
T10784	1000	1076	1116	1150	143
T10785	600 (HP)	676	716	765	158
T10786	800 (HP)	876	916	965	158
T10787	1000 (HP)	1076	1116	1165	158

Dimensions for 25X25mm Square Mounting Brackets:

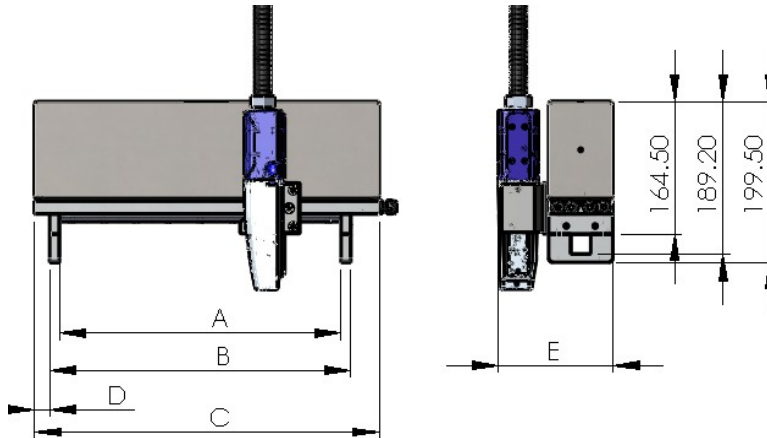

Part Number	Dimension (mm)					
	Stroke	A	B	C	D	E
T10780	280	351.5	375.5	430	19	143
T10781	440	512	536	590	19	143
T10782	600	672	696	750	19	143
T10783	800	872	896	950	19	143
T10784	1000	1072	1096	1150	19	143
T10785	600 (HP)	672	696	765	34	158
T10786	800 (HP)	872	896	965	34	158
T10787	1000 (HP)	1072	1096	1165	34	158

Dimensions for Mounting Hole Positions:

If custom mountings are to be made, the below tapped holes are available.
Holes are tapped M5

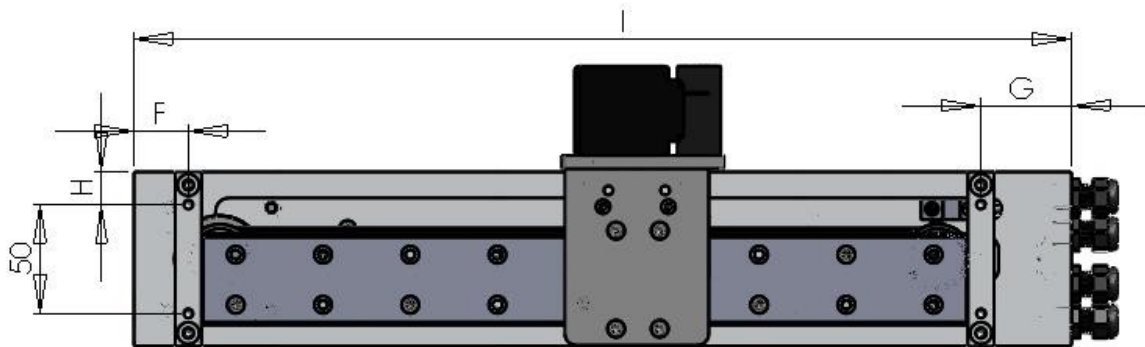

Part Number	Dimensions (mm)				
	Stroke	F	G	H	I
T10780	280	25	41.5	15	430
T10781	440	25	41	15	590
T10782	600	25	41	15	750
T10783	800	25	41	15	950
T10784	1000	25	41	15	1150
T10785	600 (HP)	40	41	30	765
T10786	800 (HP)	40	41	30	965
T10787	1000 (HP)	40	41	30	1165

HP = High Performance

WEIGHTS

Part Number	Stroke Length	Weight
T10780	280mm stroke Traverser	7kg
T10781	440mm stroke Traverser	8.5kg
T10782	600mm stroke Traverser	10kg
T10783	800mm Stroke Traverser	11kg
T10784	1000mm Stroke Traverser	12kg
T10785	600mm Stroke High Performance Traverser	13kg
T10786	800mm Stroke High Performance Traverser	16kg
T10787	1000mm Stroke High Performance Traverser	19kg

PRINT GO AND ENCODER CABLE

Print Go/Encoder cables are available to suit both i-tech/Ax and Gx printers

i-tech/Ax



Printer	Part No.	Domino Part No.
Ax /i-tech	T10810	EPT071897

Gx

Print Go/Print Reverse

A



B



Printer	Cable	Part No.	Domino Part No.
Gx150i	A	T10821	EPT071898
Gx350i/Gx OEM	B	T10819	EPT071899

Encoder



Printer	Part No.	Domino Part No.
Gx150i/Gx350i/Gx OEM	T10818	EPT071900

ACCESSORIES

Gx DOVETAIL MOUNT PLATE

The Gx dovetail mount plate is used to fit a Gx printhead to the standard traverser dovetail block.

Part No	Description	Domino Part No
T10820	Gx Dovetail Mount Plate	EPT071904

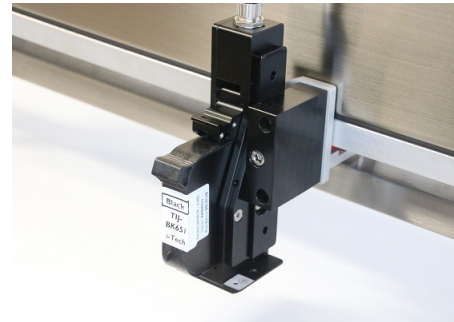

PRINT REVERSE CABLE

The printer must be set up for bidirectional printing as described in printer setup section. The Print Reverse cable is not supplied as standard and will need to be ordered separately. A splitter (Y-branch) will also be required if using Print Reverse.

Note: **Gx – Print Reverse included in Print Go cable**

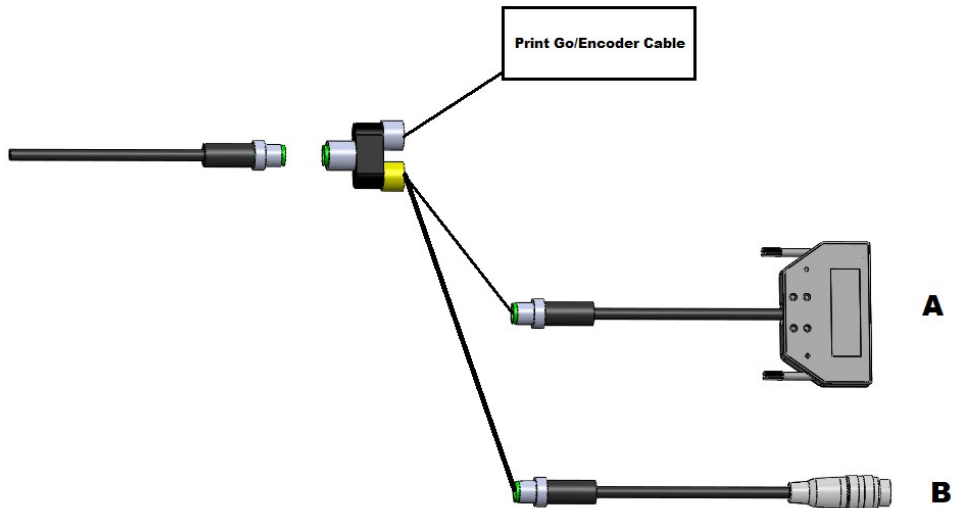

Printer	Cable	Part No.	Domino Part No.
I-tech and Ax (Extended IO Pack) 37Way	A	T10351	28877
I-tech and Ax (Extended IO Pack) 37Way IP65	A	T10584	
Ax (GPIO Pack) 14Way IP65	B	T10585	EPT071905

Part No	Description	Domino Part No.
T10197	Splitter	28870



PRINTER CABLE EXTENSION

The cable which takes Print Go, Encoder and Print reverse signals from the Traverser to the Domino A-Series is 3m long. Extension cables are available, with a length of 2m. If necessary, more than one of these cables can be joined end to end.

Part No	Description
T10204	Extension Cable (2m)



PROGRAM SELECTOR

Program selector switch boxes are available with either 8 or 16 position rotary switches.

To change program:

- Turn Selector to required program number
- Press the pushbutton to initiate the change

The program selector switch box is supplied with 3m cable, if a longer cable is required 2m extension cables are available.



Part No.	Description
T10207	Program Selector 8 Programs
T10727	Program Selector 16 Programs
T10204	Extension Cable (2m)

FOOT-SWITCH

If the Traverser is to be operator triggered a simple foot-switch is available, this switch can also be hand operated if necessary.

Part No	Description
T10205	Foot-switch



MOUNTING BRACKET OPTIONS

Mounting brackets are available to mount the Traverser on either 32mm diameter round tubing or 25mm square tubing.

- 32mm diameter brackets mount directly to standard Domino mounting system.
- 25mm square brackets mount onto mounting system available separately.

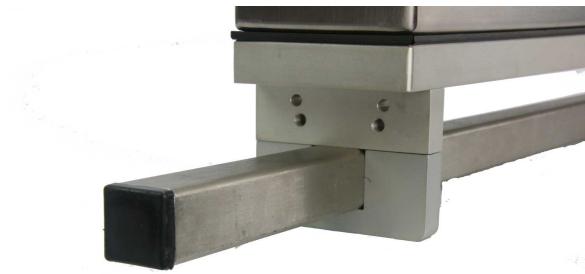

The 32mm diameter brackets allow 10mm of perpendicular movement which is useful for fine adjustment of Traverser position. Slots are provided in the brackets to accept locking rings (Domino Part No 5-0161129) these give additional anti-rotation support.

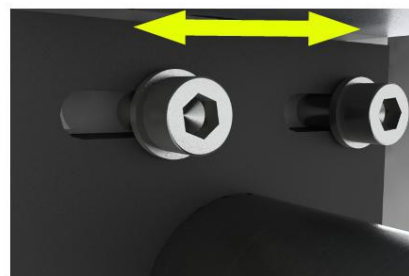

Part No	Description	Domino Part No.
T10131	Mounting Clamps 25x25mm	EPT067329
T10162	Mounting Clamps 32mm diameter	

MOUNTING SYSTEM

A 25mm rail mounting system is available as a goalpost kit in 2 different widths

T10161 Goalpost system 1m wide.

Contents: 3x 1 metre long 25x25mm stainless steel tubes.
 2x 90deg clamp blocks.
 2x pedestal clamps.
 4x end caps.

T10162 Goalpost system 1.5m wide.

Contents: 2x 1 metre long 25x25mm stainless steel tubes.
 1x 1.5 metre long 25x25mm stainless steel tubes.
 2x 90deg clamp blocks.
 2x pedestal clamps.
 4x end caps.

Individual mounting system components and lengths of rail available on request

Part No	Description
T10161	Goalpost system 1m wide
T10162	Goalpost system 1.5m wide



MOUNTING SYSTEM BASE PLATES

Mounting System Baseplates fit beneath pedestal clamps and can be bolted to the floor or an other surface. Slots allow the position of the mounting system to be varied by $\pm 10\text{mm}$. These plates are suitable for use with Domino 32mm diameter floor/wall mount clamps (5-0161126) and 25mm pedestal clamps detailed previously.

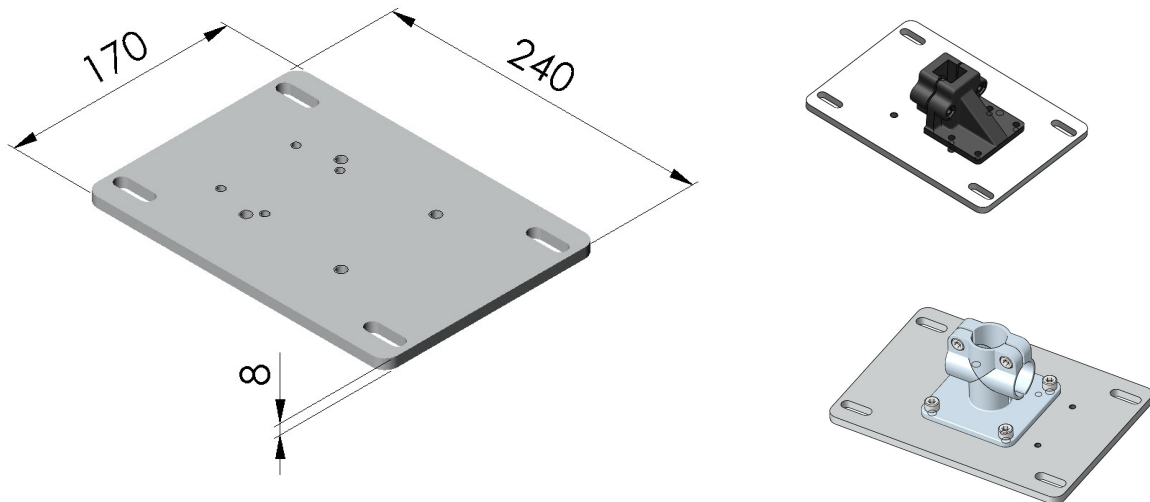

The Plates are manufactured from 8mm thick steel plate and treated with a durable powder coat finish. Also available manufactured from Stainless Steel

Part No.	Description
T10206	Mounting System Base Plates (Pair)
T10250	Mounting System Base Plates Stainless Steel (Pair)

CONDUIT SUPPORT

The conduit support kit is used to hang the conduit from a suitable fixing point above the Traverser. It supports the Conduit while also allowing the conduit to move when the traverser cycles

The Conduit Support kit consists of an adjustable length polyurethane hanger, aluminium adjustment and tensioning collars, a stainless steel snap ring to release the mounting and a stainless steel loop bracket. The loop bracket can be fitted to a suitable flat surface or used with an optional bracket to attach to either 25mm x 25mm rail or 32mm diameter rail.

Item	Part Number
1	T10208 Conduit Support Kit
2	T10209 25 x 25mm Rail Clamp
3	T10210 32mm Diameter Conduit Kit Clamp



LUBRICATION

To ensure that the Traverser maintains its high level of performance and low level of maintenance, the linear slide should be lubricated at regular intervals. The recommended interval is every 100km, however this figure is dependent on environment and conditions of use and may vary. The distance travelled by the Traverser can be monitored using the Traverser Setup software



Part No	Description
T10221	Grease Gun Kit (Supplied without grease cartridge)
T10222	Grease Cartridge 70g