

# Maximum uptime on your production line

## Service-free

- ◆ Maintaining the Ax-Series printers is effortless: replacing the i-Techx module (ITM) is a less-than-ten-minutes operator task and removes the need for traditional servicing.
- ◆ Automatic ink monitoring lets you know when consumable changes are required; you can do them in-run without stopping the line.
- ◆ Optimal ink and make-up parameters are automatically



## Always reliable

- ◆ To deliver high quality codes even in the harshest environments the robust and stackable Ax550i cabinet is made from marine grade 316 stainless steel, which is not only dust-tight but also withstands washdowns, high-pressure water blasting, and chemicals used during heavy-duty cleaning.
- ◆ To minimise errors Ax-Series printers support coding automation and integration into your ERP and MES business systems.
- ◆ Domino Cloud provides valuable production insights, helping you to improve operational efficiency and uptime.

## Up and running in no time

- ◆ Getting printers started is simple using the operator friendly single button start.
- ◆ Our iPulse printheads start up first time even after extended shutdowns thanks to Domino's unique nozzle-sealing technology.



**Ax150i** – an ideal solution for all your basic coding needs



**Ax350i** – all the flexibility CIJ has to offer



## Technical specification

	Ax150i	Ax350i	Ax550i
<b>Printing Specification</b>			
Printhead nozzles	60µm	40µm 50µm 60µm 75µm	40µm 50µm 60µm 75µm
Speed – 1 line, 5 dot characters(m/s)*	5.1	5.3 5.9 7.1 6.8	5.3 5.9 7.1 6.8
Dot size(mm)**	0.31	0.23 0.26 0.31 0.4	0.23 0.26 0.31 0.4
Print heights (single print head)		Up to 32 dots/20mm	
Print heights (Duo)	NA	Up to 64 dots/40mm	
Supported code formats		full unicode support text, graphics, 1D, 2D codes	
<b>Ownership Specification</b>			
User interface	7" Touchscreen	7" and 10.4" touchscreen options	
Conduit length	3m	3m & 6m options	
Printhead type	Straight	Straight, H90, V90, RS and Duo	
Software		<b>QuickStep 3</b>	
Comms ports		Cabinet USB port (x1); Ethernet RJ45 port (x1)	
Printer status monitoring		4 stage beacon output (x1); 3 stage alarm output (x1)	
Cartridge replacement (ink and make-up)		Auto recognition; 20 second operator task; no line stop required	
Servicing – ITM replacement		Sub 10 minute operator task. Line stop required.	
Service interval***		Typically every 12 months	
Material	304 stainless steel cabinet (5 sides) - Nylon Door	304 steel, IP55 cabinet, IP66 electronics enclosure	316 stainless steel, IP55 cabinet; IP66 electronics enclosure
<b>Consumables****</b>			
Inks	Wide range of black and coloured inks including options for food packaging, eggshells, colour change, industrial, UV-fluorescent		
Ink cartridge volume		825ml	
Make-up cartridge volume		1200ml	
<b>Optional Hardware Packs*****</b>			
Extended comms pack	NA	Cabinet USB port (x1); control port (x1); touchscreen / Ethernet port (x1)	
RS232 pack		RS232 port (x1)	
GPIO pack		I/O – 4 inputs/4 outputs (x1)	
Extended I/O pack	NA	I/O – 12 inputs / 6 outputs (x1)	
<b>Optional Performance Packs</b>			
Operator assistance pack	NA	Label templates; barcode scanning for labels and data entry; local security manager	
Green pack	NA	Up to 20% reduction in make-up emissions; configurable printhead and ink-system stand down for reduced power usage	
Continuous printing pack	NA	Dedicated user screens for faster changes during production; easier label creation; high speed print formats (ST&HS rasters)	
Advanced security pack	NA	Full security manager to secure user interface and provide customisable permissions based on individual user logins	

\*Speed quoted at the following characters per inch ----75µm = 8 characters. 60µm = 10 characters. 50µm & 40µm = 14 characters. \*\*Dot size may vary depending on substrate type. \*\*\*Dependant on ink type and ITM choice. \*\*\*\*This product has a Quality Management System that means that it will only work with Domino circuitry, and it uses dynamic security measures to block non-Domino circuitry from being used. From time to time updates to the circuitry will be issued by Domino to maintain the effectiveness of the Quality Management System. \*\*\*\*\*May vary per sales region

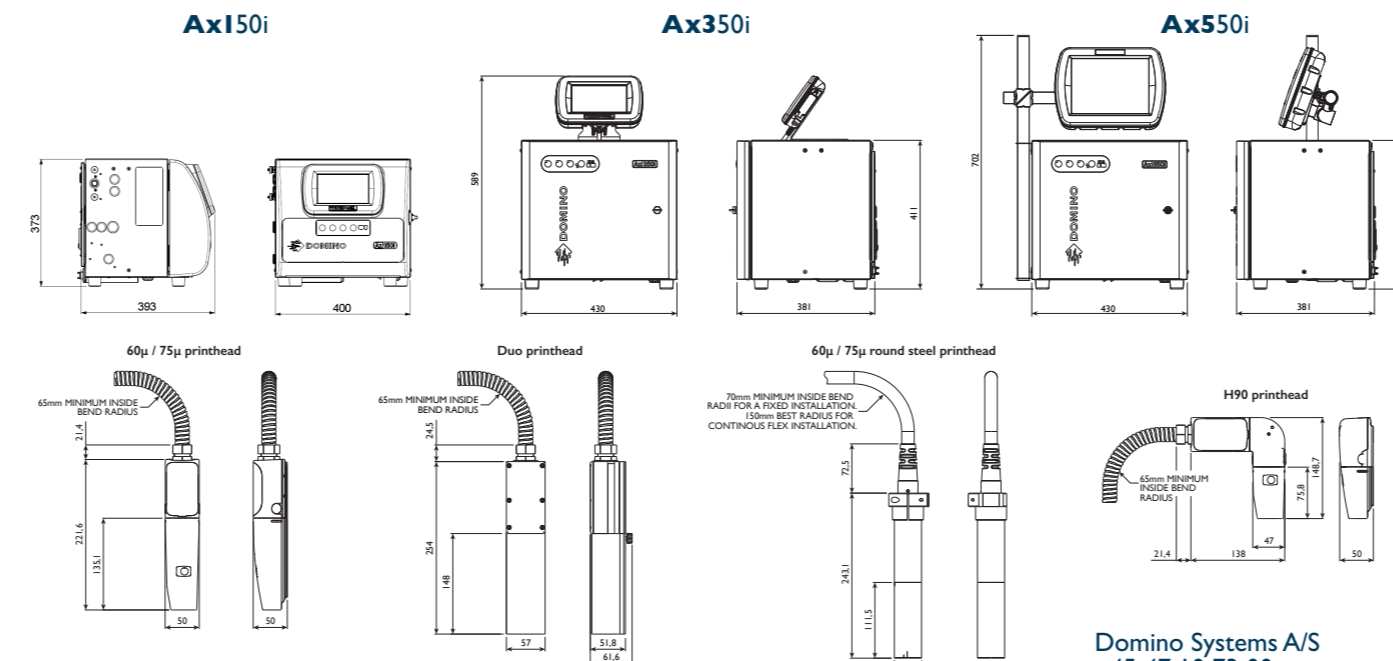

[www.dominosystems.dk](http://www.dominosystems.dk)



# Ax-Series Continuous Ink Jet Printers

Flexible coding solutions for Industry 4.0



Speed, accuracy and the ability to perform in the toughest environments give our Ax-Series printers the leading edge.



Domino Systems A/S  
+45 47 10 73 00  
Marielundvej 46 A  
2730 Herlev, Danmark



# Designed to boost production effectiveness

The Ax-Series printers are an easy to operate coding solution for all your date coding, traceability or product branding requirements.

The Ax-Series is compatible with Industry 4.0 standards. Connecting to Domino Cloud enables remote diagnostics and 24/7 visibility of your printers' performance. The intuitive touchscreen user interface provides a class-leading user experience.

Domino's service-free ink system with our i-Pulse printhead technology ensures high code quality even in tough production environments.

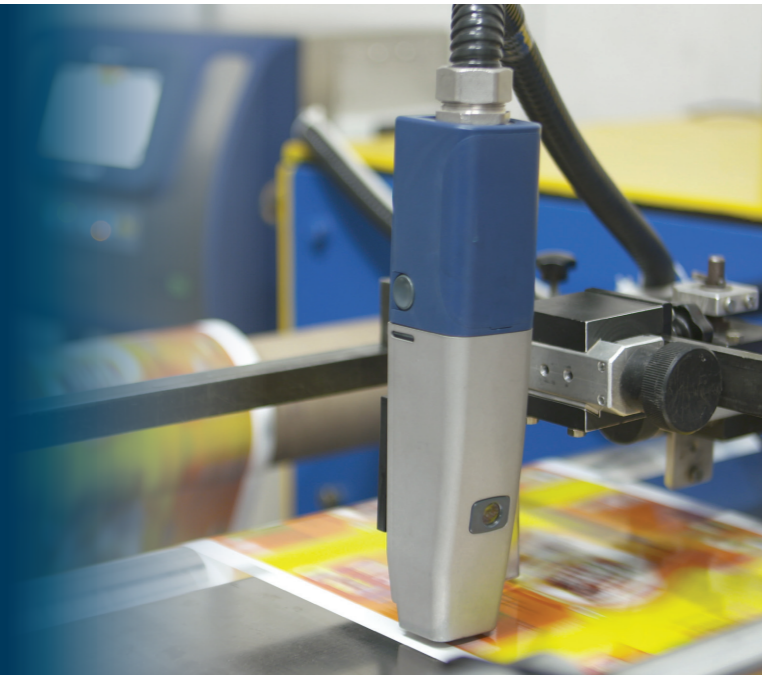

## Food and Beverage

Demanding production schedules, no problem! Ax-Series delivers maximum flexibility & uptime on your production lines. Whether it's filler integration and intelligent traceability coding, a washdown environment or need for Industry 4.0 connectivity, Ax-Series has you covered.



## Industrials

Product Identification and Parts Marking require quality codes lasting the product lifetime. Our user-friendly Ax-Series printers deliver durable, impactful large codes onto extruded building materials, MRCs onto electronics or small text onto cables in a broad range of colours.



## Medicines and Personal Care

When consumer safety and product quality are paramount, Domino is the ideal coding partner. Underpinned by our expertise in printing legislation and machinery validation, the Ax-Series offers integration with leading vision systems, validation documentation and compliant inks for a complete quality coding solution.



Domino has established a global reputation in continuous ink jet coding and has been setting the industry standard for quality, reliability and versatility for over 40 years.

# Consistent quality codes

The Ax Series is a non-contact coding solution that can print high quality codes on virtually any surface and product; whether flat, round, uneven or moving.

## i-Pulse technology

The i-Pulse printhead technology is a step change in CIJ coding. Best readability and best reliability at faster speed in a higher 9-drop resolution (versus traditional 7 drops) plus saving up to 24% in ink usage result from optimised ink drop formation.

To meet the coding needs for your operating environment, substrate and data format, Domino has designed a range of i-Pulse printheads:

- ◆ For easy installation onto confined production lines, Domino offers horizontal and vertical, 90-degree angled printheads. Rotatable heads are also available for easy alignment on narrow products.



### Logos and 2D Codes



### Multi Language and Mixed Fonts



## Domino inks

- ◆ Domino supplies a range of inks manufactured to GMP (Good Manufacturing Practice) which are compliant with leading global legislation for food packaging.
- ◆ Designed to support a wide range of applications, our i-Pulse inks easily adhere even after harsh post-print processes.
- ◆ Inks are available in a range of vivid colours producing highly durable codes for the lifetime of your product.
- ◆ Environmental-friendly fluid options, reduced ink consumption, optimised packaging, fully-depleting cartridges and reduced footprint contribute to improved sustainability.

- ◆ 60µ and 75µ printheads are a great choice for applications across many industries. The highly durable, hygienic round steel variants with extruded, smooth conduit are designed for tough operating and washdown environments.
- ◆ 40µ and 50µ printheads are ideal for applications requiring precise 2D and human readable codes on components of all shapes and sizes.
- ◆ The Duo printhead uses twin jets to produce up to 10 lines of text or print at twice the speed.



# Connected for automation and service

## Think integration

With increased demand for improved traceability of products the need for code accuracy is greater than ever. By taking control centrally you can simplify the creation and management of codes making product change overs simple and error free.

- ◆ The Ax-Series integrates to Domino's Coding Automation solutions and third party control systems to deliver production line automation.
- ◆ Connection to Domino Cloud enables remote printer performance overviews and remote diagnostics.
- ◆ Ensure the readability of every code: the R-Series, Domino's vision system has been developed for our printers to automatically check every code, eliminate labour-intensive manual inspections, reduce the amount of scrap and avoid the expense and brand damage of recalls.

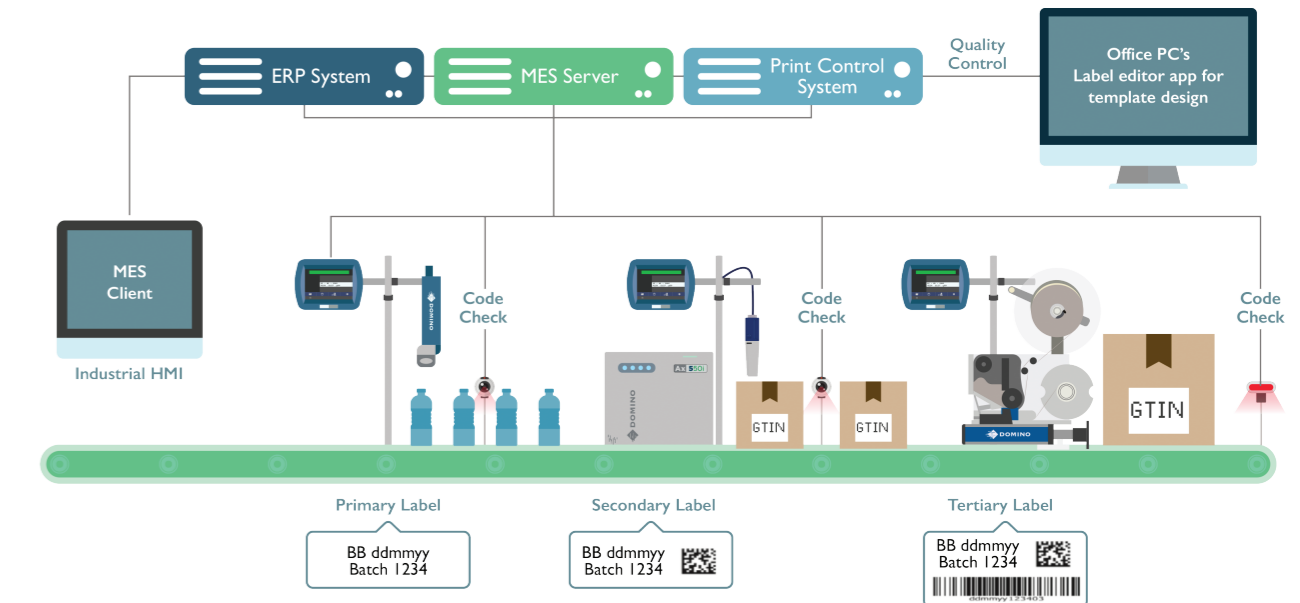

## A complete solution

Our services are designed to provide operational insight so you can eliminate downtime and maximise production efficiency

### Operational support

An outstanding level of care, wherever you are. Our SafeGuard packages provide high-quality, on-site assistance and AR-enabled remote guidance from our engineers. SafeGuard helps to ensure we can be with you when you need us most.

### Automatic code inspection

Ensure every code that leaves your factory is present and correct, and free up operator time. With the R-Series, Domino's range of vision control systems, you can automate your code inspection to validate code presence, placement, and readability.

### Control software

Minimise errors using Domino's QuickDesign software. Control your product codes from a central location and streamline product changeovers. QuickDesign uses standard communication protocols and can be integrated into existing ERP systems.

### Smart production

Gain operational insight by connecting your printer to Domino Cloud. Obtain production analytics dashboards and receive system error alerts. Domino Cloud provides you with the information you need to run your operations more efficiently.